

Port Washington Water District

38 Sandy Hollow Road, Port Washington, NY 11050 ☎ (516) 767-0171 ☎ (516) 767-1145-Fax

Application for Installation of an Underground Irrigation System



NOTE: No work is to be performed on installations of either the Irrigation System or the Backflow Prevention Assembly until the plans have been received and approved, in writing, by the Board of Commissioners of the Port Washington Water District and/or the Superintendent.

All information must be complete

Date: ____/____/20____

*Account Number: _____
* (Completed by District)

Owner's full Name: _____
(First Name) (M.I.) (Last Name)

Address of Premises: _____
(Street) (Town/City) (State/Zip)

Home Ph#: (____) _____ Work#: (____) _____ E-Mail: _____
(Optional)

Owner's Address (if *different* from above):

(Street Address) (Town/City) (State/Zip)

Irrigation System Installer Name: _____ Phone: (____) _____

Installer's Address: _____
(Street) (Town/City) (State/Zip)

Installer's Nassau County License Number: _____

Plumber's Name: _____ Phone: (____) _____

Plumber's Address: _____
(Street) (Town/City) (State/Zip)

➤ **Please be advised that when submitting this application, a \$165.00 processing fee must accompany it.**

The following information must accompany this application

1. **Rainfall Sensing Equipment:**

Type: _____ Manufacturer: _____ Size: _____

2. **Backflow Prevention Device:**

➤ New: Existing: Size: _____
 Manufacturer: _____ Date of Latest Test: ___/___/___

3. **Irrigation System Controller*:**

Manufacturer: _____ Model Number: _____

*Must be a Smart Controller and have EPA WaterSense label

4. A formal sketch of the irrigation zone valve vault showing the arrangement of the pressure regulating valve, timer and zone manifold.

NOTE: TOTAL WATER FLOW RATE IN THE SYSTEM IS NOT TO EXCEED 10 GALLONS PER MINUTE PER ZONE. ALSO, ALL DRAWINGS MUST BE LEGIBLE.

5. **A survey drawing or site plan of the premises that show the following:**

- A. Dimensions of the site.
- B. All individual zones outlined in dashed lines showing sprinkler heads, piping arrangement, location and size.
- C. Location of meter, outside locking type ball valve, backflow prevention device and irrigation pipe connection to house plumbing system.
- D. Manufacturer's catalog describing the automatic 31-day adjustable calendar-type clock timer device to be used to control the irrigation periods.
- E. Any work on the service line or backflow prevention device must be done by a licensed plumber.
- F. The irrigation design should include a pressure loss worksheet for the zones with the highest flow and furthest from the source, listing the following:
 - Valve number and flow rate
 - Available static water pressure
 - Loss or gain due to elevation
 - Detailed list of various component pressure losses & velocities
 - The operating pressure requirements
- G. **Tabulation of system by zones:**

Zone No.	Manufacturer	Sprinkler Head Catalog No.	Sprinkler Head Capacity (gpm)	Sprinkler Head Capacity Rating per Catalog (gpm)	Number of Heads in Zone (each)	Total flow from Heads by Zone (gpm)

- ➔ **Installation must conform to the Port Washington Water District's Standard Drawings and Requirements.**

The following plans were approved by the Port Washington Water District:

BY:  _____

DATE: ____/____/____

NOTE: Irrigation water use at the premises under this application shall not exceed _____ gallons per year. ← (To be completed by District)

- The quantity of irrigation water to be obtained from the Port Washington Water District is based upon the following:
1. The area under irrigation does not exceed forty percent (40%) of the gross lot area.
 2. The annual irrigation period does not exceed 30 weeks per year (April to October).
 3. Irrigation requirement does not exceed 1 inch (1") of water application per week, of which fifty percent (50%) is supplied by natural precipitation.

Conditions of Approval:

1. The Port Washington Water District requires that a Double Check Valve or Backflow Prevention Device be installed at the meter arrangement on the incoming water service line. This is a requirement for application approval.
2. Nassau County Department of Health requires that a fully completed application form (DOH-347) signed by the District along with an approved Double Check Valve drawing and the appropriate fee be sent to the NCDOH for review and final approval. ***Please note that they require four sets of the application and drawing.
3. Installation of meters and backflow devices must be according to District standard drawings.
4. Upon completion of installation, a completed form DOH-1013, "Report on Test and Maintenance of Backflow Prevention Device", must be completed by a certified backflow device tester. This must be forwarded to our Board of Commissioners of the Port Washington Water District with thirty (30) days of installation of the device.

NOTE: On new backflow prevention devices, the District will do the initial test during their inspection. All other annual tests are the owner's responsibility.

5. Notify the Port Washington Water District upon completion of the sprinkler system installation to enable our representative to inspect the final installation for compliance with the plans and specifications.

 ***Pages 1-3 are to be completed & returned to the District.***

Rules and Regulations for Installation of Underground Irrigation Systems in the Port Washington Water District

All new Underground Irrigation Systems shall comply with the following requirements:

1. Irrigation designer shall be a Certified Irrigation Designer as certified by The Irrigation Association, or other professional with extensive experience in the design of irrigation systems as determined by the District Superintendent.
2. The irrigation design should include a pressure loss worksheet for the zones with the highest flow and furthestmost from the source, listing the following:
 - Valve number and flow rate
 - Available static water pressure
 - Loss or gain due to elevation
 - Detailed list of various component pressure losses & velocities
 - The operating pressure requirements
3. Pop-up spray heads for turf areas shall have a minimum pop-up height of 4". A 4" pop-up height shall be used adjacent to streets. The 12" pop-up height will be used in ground cover and flowerbeds. Heads shall have a ratcheting feature for adjusting the direction of spray. Pop-up spray heads shall have a pressure regulating device (set at 30psi) installed in the base of the stem, a check valve installed in the base of the body, and slotted plastic nozzles, with matched precipitation rate nozzles.
4. Use an internal drive, closed case rotor with wiper seals and spring retraction. Pop-up stem surface diameter shall be less than 2-inches, and a minimum pop-up height of 4-inches. All heads shall have check valves built into the bottom of the body. Use small radius rotor heads for areas that range from 20 feet to 30 feet wide.
5. Residential Customers are encouraged to use continuously self-flushing, pressure-compensating subsurface drip irrigation with check valves in non-cultivated planting beds that are mulched or in narrow turf strips where spray heads are not practical. As with sprinkler irrigation, drip irrigation shall be zoned for varying plant needs, slopes, and exposures. Drip irrigation shall include check valves.
6. Areas of non-turf commercial property shall be restricted to continuously self-flushing, pressure-compensating subsurface drip irrigation. As with sprinkler irrigation, drip irrigation shall be zoned for varying plant needs, slopes, and exposures and shall include check valves.
7. A Smart Controller EPA WaterSense labeled automatic adjustable calendar-type clock timer device, with capability to skip days, and capable of programming odd or even irrigation days, shall be installed and programmed to automatically operate and allow irrigation water use at the premises only during the days and hours permitted under the District's Water Conservation Program's latest notice. The automatic ON-OFF time-controlled irrigation system is to remain OFF during the period between the permissible irrigation days and times. The clock or timing device should also run properly with the 31-day months.

8. A rainfall sensing device shall be installed to automatically turn the irrigation system OFF when it rains during the irrigation periods, and to skip a subsequent irrigation period when it has rained prior to the irrigation period and/or when the soil moisture conditions in the soil in the area under irrigation are adequate for plant growth without further addition of water. The device shall be adjusted to shut down irrigation and/or to skip the subsequent irrigation period when a total of ½" of precipitation occurs any time between one cycle (two days).
9. The calendar period during which irrigation shall be permitted is from April 15th to October 31st.
10. Pressure regulating valve, spring loaded, installed on the upstream side of the zone valve manifold. Only one pressure-regulating valve is to be used for the system and shall be set to maintain inlet water pipe pressure to the irrigation system at a level not to exceed five pounds per square inch above the manufacturer's rated pressure, for the highest pressure rated sprinkler head in use in the most flow-demanding zone in the irrigation system. Threaded connections, pet cock and pressure gauge, installed between the pressure-regulating valve and the manifold. Pressure at all heads should be within 10 percent of the system design operating pressure. Example: A head designed for 30.0 PSI should operate within the 27.0 to 33.0 PSI range. This shall be accomplished by using pressure-reducing valves (not flow control valves or flow restriction devices) installed under or in the base/stem of the head.
11. Total lot area under irrigation shall not exceed 40 percent (40%) of the gross lot area.
12. A locking ball valve shall be installed outside the building on the water feed line to the irrigation system in a location accessible to District personnel for the purpose of shutting down the system during emergencies or when violations of these Rules and Regulations has occurred.
13. New underground irrigation system shall be designed and modified to restrict total annual irrigation water use to the amount approved by the Port Washington Water District and shown on the approved application form filed by the owner.
14. For slopes in excess of a 3 to 1 ratio, heads placed at the bottom of a slope need to be valved separately. Mid-point on the slope will need a moderate amount of water and therefore these heads shall also have their own zone. Heads placed on the top of the slope must be valved separately, as they will water for the longest period of time because this section will have no run-off from above and is exposed to more sun and wind. Lateral lines on slopes shall be installed along the contour rather than up and down the slopes. Total water flow rate in the system shall not exceed 10 gallons per minute per zone.

Heads placed at the bottom of a slope need to be valved separately. Mid-point on the slope will need a moderate amount of water and therefore these heads shall also have their own zone. Heads placed on the top of the slope must be valved separately, as they will water for the longest period of time because this section will have no run-off from above and is exposed to more sun and wind. Lateral lines on slopes shall be installed along the contour rather than up and down the slopes. **Total water flow rate in the system shall not exceed 10 gallons per minute per zone.**

15. A double check valve backflow device shall be installed at the meter on the incoming water service feeding the premises in accordance with Port Washington Water District statutes for installation and approval of the backflow prevention devices. This is a requirement for approval of application.
16. The owner files an application to the Superintendent of the Port Washington Water District for installation of an underground irrigation system and receives an approval of application by the Superintendent.
17. A landscape irrigation audit must be performed every 5 years by an auditor approved by the District and a copy of the audit shall be provided to the district.



Pages 4 & 5 are to be retained by the Irrigation System Installer for their use.

Port Washington Water District

💧 *Water Conservation Program* 💧

All new Irrigation Installations shall conform to District Rules and Regulations for Operation of Underground Irrigation Systems in the Port Washington Water District.

1. **IRRIGATION:** Use of water for irrigation purposes for lawn, shrubs, trees, plants and vegetation of any type is permitted only under the following conditions: There will be no watering between the hours of 10am and 4pm on any day. Odd numbered addresses may irrigate for a maximum of two hours on odd numbered days; even numbered addresses may irrigate for a maximum of two hours on even numbered days. Premises without an address may irrigate on even numbered days for a maximum of two hours. The Board may change either the days of the hours or both, if it is considered necessary to protect the District water supply and/or pressure.
2. **HOSE USE:** All hoses must be fitted with a nozzle.
3. **SWIMMING POOLS:** Pools must be equipped with a recirculation and filtering system. Pool operation must conform to special conditions for the use of a swimming pool over 2500-gallon capacity prepared by the Port Washington Water District.
4. **PONDS AND LAKES:** Use of water for filling ponds, lakes or any natural or manmade body of water, or using water for makeup or to maintain designated water levels in ponds, lakes or any natural or manmade body of water, is prohibited.
5. **SPRAY PONDS AND FOUNTAINS:** The use of water for outdoor spray ponds or fountains, using re-circulated water in excess of five gallons per minute, whether used for decorative or other purposes, is prohibited.
6. **FLUSHING STREETS, WALKS AND DRIVEWAYS:** Use of water for flushing and spraying public streets, sidewalks and private driveways for any purpose is prohibited.
7. **CAR WASH:** Commercial car wash establishments must be equipped with re-circulation facilities to re-use rinse water as approved by the Port Washington Water District.
8. **COOLING WATER USE:** Cooling water for any purpose, including but not limited to air conditioning, refrigeration, engine cooling and condensation, is prohibited. New equipment designed to utilize water for cooling purposes, installed after September 30th, 1988 will not be supplied with water from the District system. All existing equipment utilizing water for cooling purposes, including the new equipment installed prior to September 30th, 1988, shall be replaced with equipment that does not require water at a rate in excess of 0.1 gallons per minutes of water per ton of installed capacity prior to June 30th, 1989.
9. **EARTH COMPACTING:** Use of water for compacting earth backfill by jetting, puddling, or by any other method which utilizes water, is prohibited.
10. **INCREASING BLOCK RATE:** Block rates for water supply will be established by the Board.
11. **WATER CONSERVATION FIXTURES:** The Board will establish a program to advise consumers on methods of retrofitting existing plumbing fixtures to water conservation type fixtures. To ensure that all new plumbing fixtures installed in premises within the District are flush type water conservation valves, tank type fixtures only will be accepted.
12. **PLUMBING SYSTEM - OPERATION AND MAINTENANCE:** The Board shall institute a public information program concerning proper operation and maintenance of plumbing fixtures to conserve water and prevent waste.
13. **PROGRAM FOR LARGE WATER USERS:** The District shall establish a program to meet and discuss water needs and water use with large consumers to develop means to affect a 10% or more reduction in water use.

➔ *THIS FORM TO BE RETAINED BY HOMEOWNER*

SYSTEM PRESSURE LOSS WORKSHEET

Underground Irrigation System

Company Name: _____

Company Address: _____

Project Name & Address: _____

COMPONENTS	TYPE/SIZE	LENGTH	LOSS or LOSS/100'	PRESSURE LOSS/GAIN
1. Needed by Sprinkler:				
2. Losses: Lateral Pipe:				
Main Line Pipe:				
Lateral & Main Line Fittings:				
Zone Valve:				
Master Valve:				
Backflow Prevention Device				
Pipe to Backflow:				
Main Valve:				
Pipe to POC:				
Water Meter:				
Service Line to Meter:				
Fittings:				
Miscellaneous:				
Miscellaneous:				
3. Elevation (Loss or Gain):				
4. Total Pressure Required:				

Static Pressure		PSI
Total System Losses:		PSI
Pressure at last head:		PSI

Req'd. Operating Pressure		PSI
Over/Under		PSI

Application for Approval of Backflow Prevention Devices

PRINT OR TYPE ALL ENTRIES EXCEPT SIGNATURES
 Please completed items 1 through 12a + Block and Lot Numbers

Block #	Lot #	FOR DEPARTMENT USE ONLY Log No.
---------	-------	------------------------------------

1. Name of Facility	2. City, Village, Town	3. County
4. Location of Facility <small>Street</small>	<small>City</small>	<small>state</small>
4a. Phone Numbers	5. Contact Person	
5. Approx. Location of Device(s)	6. Mfg. Model #	Size of Device(s)

# of Fire Services	# of Domestic Services	# of Combined Services	Total # of Services	Total # of Buildings
--------------------	------------------------	------------------------	---------------------	----------------------

7. Name of Owner	Title	Phone Number	8. Nature of works <input type="checkbox"/> Initial Device Installation <input type="checkbox"/> Replace Existing Device
Full Mailing Address <small>street</small>			8a. <input type="checkbox"/> New Service <input type="checkbox"/> Existing Service
Address <small>City</small>			8b. <input type="checkbox"/> New Building <input type="checkbox"/> Existing Building <input type="checkbox"/> Major Renovations
Owner's Signature			Date <u> </u> / <u> </u> / <u> </u> <small>M D Y</small>

9. Name of Design Engineer or Architect	10. NYS License #				
<div style="border: 1px solid black; padding: 5px; width: fit-content;"> NCDH approved typical plan is being used </div>	<input type="checkbox"/> PE <input type="checkbox"/> RA <input type="checkbox"/> Other				
<table border="1" style="width: 100%; border-collapse: collapse;"> <tr> <td style="width: 80%; padding: 2px;"><small>Street</small> Address</td> <td style="width: 20%; padding: 2px;"><small>City</small></td> </tr> <tr> <td style="padding: 2px;"><small>State</small></td> <td style="padding: 2px;"><small>Zip</small></td> </tr> </table>	<small>Street</small> Address	<small>City</small>	<small>State</small>	<small>Zip</small>	10a. Telephone Number(s)
<small>Street</small> Address	<small>City</small>				
<small>State</small>	<small>Zip</small>				
Original Ink signature and seal required on all copies _____ Signature	Date <u> </u> / <u> </u> / <u> </u> <small>M D Y</small>				

11. Water System Pressure (psi) at Point of Connection <small>Max</small> _____ <small>Avg</small> _____ <small>Min</small> _____	12. Estimate Installation Cost	12a. Estimate Design Cost
--	--------------------------------	---------------------------

13. Degree of Hazard <input type="checkbox"/> Hazardous <input type="checkbox"/> Aesthetically Objectionable	List of processes or reasons that lead to degree of hazard checked: _____ _____
--	---

14. Public water supply name Port Washington Water District Mailing Address 38 Sandy Hollow Road <small>street</small> Port Washington NY 11050 <small>City state zip</small> Telephone No. (516)767-0171	Name of supplier's designate representative Title Paul Prignano, Superintendent Signature _____ <small>M D Y</small>
---	---

Note: All applicants must be accompanied by plans, specifications and an engineer's report describing the project in detail. The project must first be submitted to the water supplier, who will forward it to the local public health engineer. This form must be prepared in quadruplicate with four copies of all plans, specifications and descriptive literature.

F:\269876\figures\269876-Double Check Valve Basement.dwg, Layout1, 4/24/2026 11:24:56 AM, DBCadd

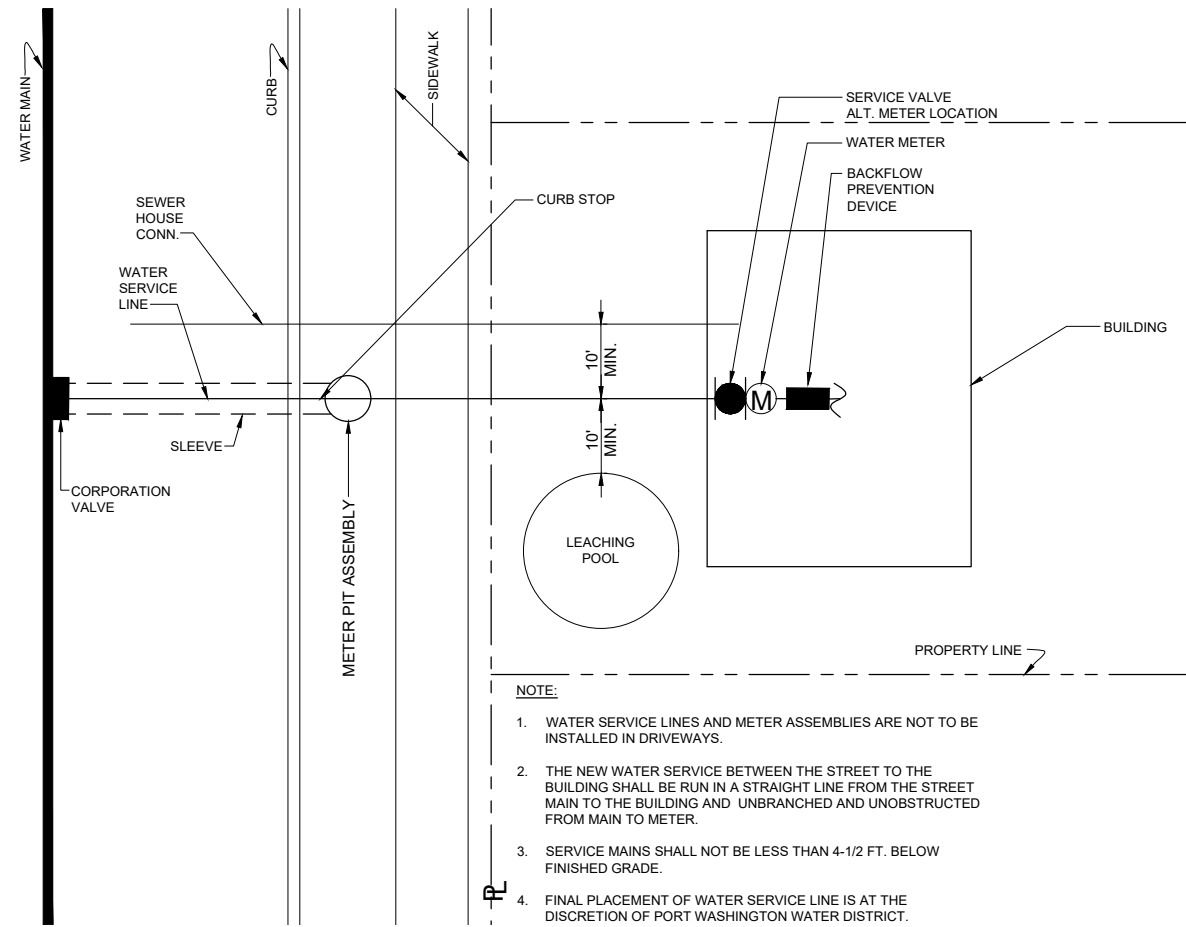

- NOTE:**
1. WATER SERVICE LINES AND METER ASSEMBLIES ARE NOT TO BE INSTALLED IN DRIVEWAYS.
 2. THE NEW WATER SERVICE BETWEEN THE STREET TO THE BUILDING SHALL BE RUN IN A STRAIGHT LINE FROM THE STREET MAIN TO THE BUILDING AND UNBRANCHED AND UNOBSTRUCTED FROM MAIN TO METER.
 3. SERVICE MAINS SHALL NOT BE LESS THAN 4-1/2 FT. BELOW FINISHED GRADE.
 4. FINAL PLACEMENT OF WATER SERVICE LINE IS AT THE DISCRETION OF PORT WASHINGTON WATER DISTRICT.

PLOT PLAN

SCALE: N.T.S.

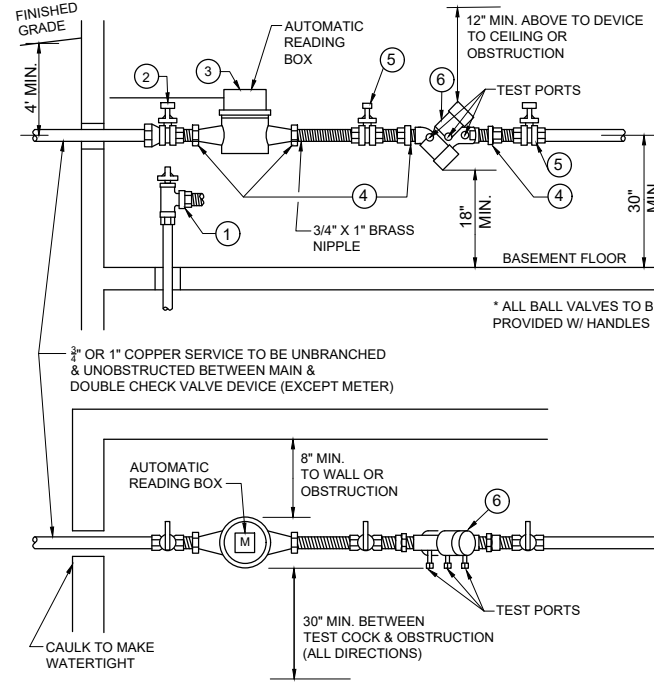

- (1) 3/4" OR 1" ANGLE BALL VALVE W/ METER CPLG. (ALTERNATE SETTING)
- (2) 3/4" OR 1" STRAIGHT BALL VALVE
- (3) 3/4" OR 1" WATER METER (SET HORIZONTALLY)
- (4) 3/4" OR 1" STRAIGHT METER CPLG. W/ GASKET
- (5) 3/4" OR 1" BALL VALVE W/ HANDLE
- (6) 3/4" OR 1" DOUBLE CHECK VALVE (DCV) W/ 1-1/4" BRASS NON-TAPERED BUSHINGS

TYPICAL INSIDE BASEMENT INSTALLATION PLAN AND ELEVATION

SCALE: N.T.S.

GENERAL NOTES:

1. INSTALLATION SHALL MEET ALL N.C.D.H. AND N.Y.S.D.O.H. REQUIREMENTS.
2. BACKFLOW DEVICE SHALL BE PROTECTED FROM FLOODING AND FREEZING AT ALL TIMES.
3. PIPING SHALL BE UNBRANCHED AND UNRESTRICTED FROM MAIN TO DEVICE EXCEPT FOR METER.
4. AN INITIAL TEST OF THE DEVICE SHALL BE PERFORMED BY A NYSDOH CERTIFIED TESTER PRIOR TO THE DEVICE BEING PLACED INTO SERVICE. NYSDOH FORM # DOH-1013 (REPORT ON TEST AND MAINTENANCE OF BACKFLOW PREVENTION DEVICE) SHALL BE COMPLETED IN ITS ENTIRETY AND ALL SATISFACTORY TEST RESULTS SHALL BE FORWARDED TO PORT WASHINGTON WATER DISTRICT AND NASSAU COUNTY DEPARTMENT OF HEALTH.
5. IT IS THE PROPERTY OWNER'S RESPONSIBILITY FOR THE BACKFLOW PREVENTION DEVICE TO BE TESTED AND INSPECTED AT LEAST ANNUALLY BY A NYSDOH CERTIFIED BACKFLOW TESTER WITH RESULTS REPORTED TO PORT WASHINGTON WATER DISTRICT USING NYSDOH FORM # DOH-1013".
6. DISCHARGE FROM BACKFLOW DEVICE TO BE POSITIVE WITH EFFLUENT VISIBLE WITH DISCHARGE ABOVE HIGHEST POSSIBLE FLOODING LEVEL.
7. ALL WATER SERVICE PIPING AND FITTINGS SHALL BE CERTIFIED "LEAD-FREE" MATERIALS.
8. THE PROPOSED BACKFLOW PREVENTION DEVICE SHALL BE LEAD FREE AND SHALL BE FROM A LIST OF APPROVED BACKFLOW PREVENTION DEVICES BY UNIVERSITY OF SOUTHERN CALIFORNIA (USC).
9. BACKFLOW DEVICE TO BE ONE SIZE LARGER WHERE PRESSURE IS LOW OR CRITICAL.
10. BACKFLOW DEVICE SHALL BE INSTALLED IMMEDIATELY AFTER THE METER, IF POSSIBLE. IF THE DEVICE IS NOT IN THE SAME LOCATION AS THE METER, OR IS EVER GREATER THAN 10-FEET FROM THE METER A NOTE STATING THAT ALL PIPING NOT PROTECTED BY BACKFLOW DEVICES SHALL BE STENCILED "FEED LINE TO RPZ/DCV DO NOT TAP" AT 5-FOOT INTERVALS.

PROPOSED BACKFLOW PREVENTION DEVICE

MANUFACTURER _____ MODEL _____

ADDRESS _____

ENDORSED BY THE PORT WASHINGTON WATER DISTRICT FOR INSTALLATION OF A _____ (SIZE) DOUBLE CHECK VALVE

BY _____ DATE _____

**REQUIRED SEPARATION DISTANCES
RECOMMENDED STANDARDS FOR WATER WORKS
CLEARANCES BETWEEN WATER MAINS & SEWER & STORM DRAINS
NEW YORK STATE DEPARTMENT OF HEALTH**

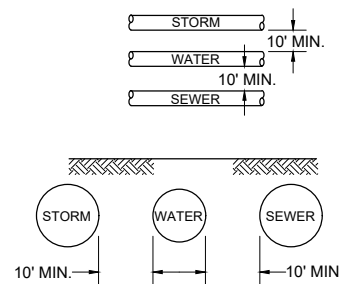

- NOTE:** LAYED IN SEPARATE TRENCH OR UNDISTURBED EARTH SHELVE LOCATED ON ONE SIDE OF THE SEWER.
- a. SEWER TO BE CONSTRUCTED OF SLIP-ON OR MECHANICAL JOINT CAST IRON PIPE.
 - b. PRESSURE TESTED TO ASSURE WATER TIGHTNESS BEFORE BACKFILLING.

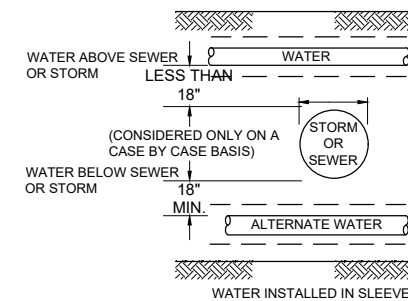
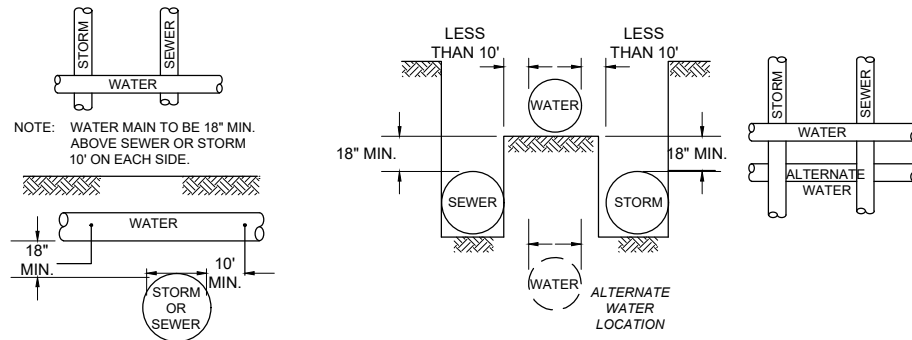

F:\269876\figures\2026-04-24\269876-Meter Pit Installation-Layout1.dwg, Layout1, 4/24/2026 11:13:05 AM, DBCadd

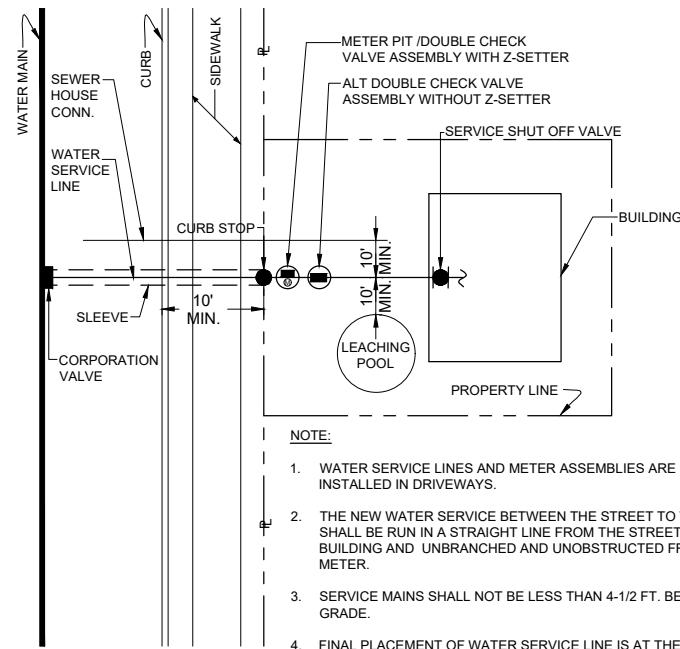

PLOT PLAN
SCALE: N.T.S.

- NOTE:**
1. WATER SERVICE LINES AND METER ASSEMBLIES ARE NOT TO BE INSTALLED IN DRIVEWAYS.
 2. THE NEW WATER SERVICE BETWEEN THE STREET TO THE BUILDING SHALL BE RUN IN A STRAIGHT LINE FROM THE STREET MAIN TO THE BUILDING AND UNBRANCHED AND UNOBSTRUCTED FROM MAIN TO METER.
 3. SERVICE MAINS SHALL NOT BE LESS THAN 4-1/2 FT. BELOW FINISHED GRADE.
 4. FINAL PLACEMENT OF WATER SERVICE LINE IS AT THE DISCRETION OF PORT WASHINGTON WATER DISTRICT.

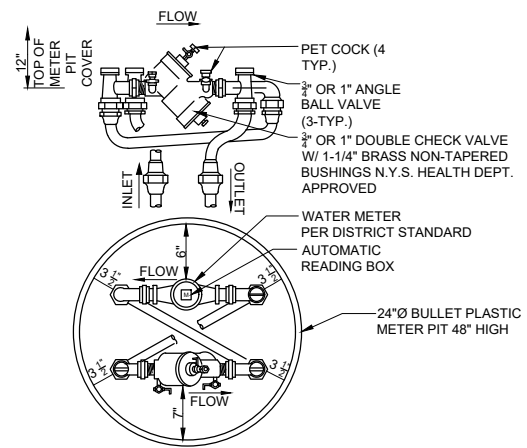

TYPICAL METER PIT INSTALLATION PLAN AND ELEVATION

SCALE: N.T.S.

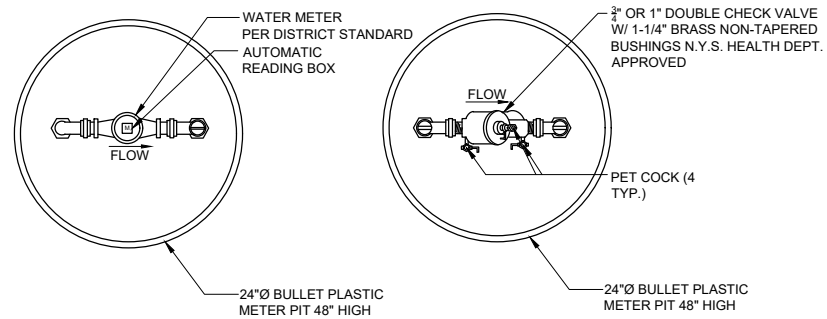

ALTERNATE TYPICAL METER PIT INSTALLATION PLAN AND ELEVATION

SCALE: N.T.S.

REQUIRED SEPARATION DISTANCES
RECOMMENDED STANDARDS FOR WATER WORKS
CLEARANCES BETWEEN WATER MAINS & SEWER & STORM DRAINS
NEW YORK STATE DEPARTMENT OF HEALTH

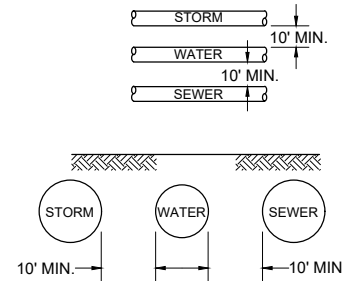

NOTE: LAYED IN SEPARATE TRENCH OR UNDISTURBED EARTH SHELF LOCATED ON ONE SIDE OF THE SEWER.

- a. SEWER TO BE CONSTRUCTED OF SLIP-ON OR MECHANICAL JOINT CAST IRON PIPE.
- b. PRESSURE TESTED TO ASSURE WATER TIGHTNESS BEFORE BACKFILLING.

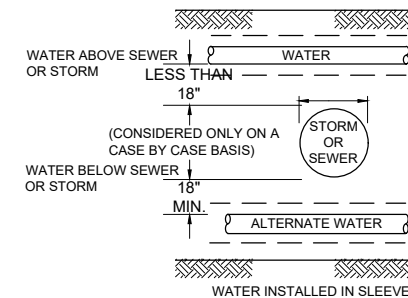
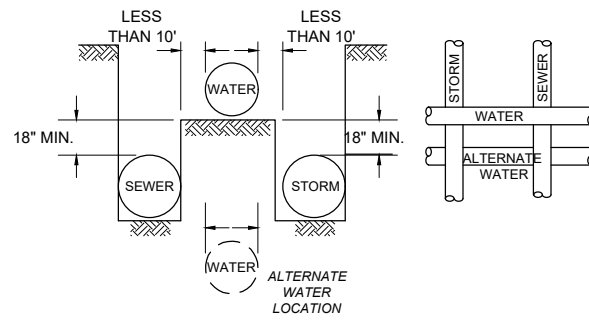
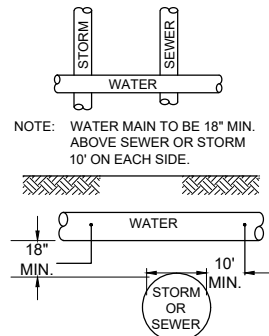

GENERAL NOTES:

1. INSTALLATION SHALL MEET ALL N.C.D.H. AND N.Y.S.D.O.H. REQUIREMENTS.
2. BACKFLOW DEVICE SHALL BE PROTECTED FROM FLOODING AND FREEZING AT ALL TIMES.
3. TOP OF WATER TIGHT PIT WITH DCV SHALL BE A MINIMUM OF 6-INCHES ABOVE GRADE AND GROUND AROUND IT SHALL SLOPE AWAY FOR POSITIVE DRAINAGE.
4. PIPING SHALL BE UNBRANCHED AND UNRESTRICTED FROM MAIN TO DEVICE EXCEPT FOR METER.
5. AN INITIAL TEST OF THE DEVICE SHALL BE PERFORMED BY A NYSDOH CERTIFIED TESTER PRIOR TO THE DEVICE BEING PLACED INTO SERVICE. NYSDOH FORM # DOH-1013 (REPORT ON TEST AND MAINTENANCE OF BACKFLOW PREVENTION DEVICE) SHALL BE COMPLETED IN ITS ENTIRETY AND ALL SATISFACTORY TEST RESULTS SHALL BE FORWARDED TO PORT WASHINGTON WATER DISTRICT AND NASSAU COUNTY DEPARTMENT OF HEALTH.
6. IT IS THE PROPERTY OWNER'S RESPONSIBILITY FOR THE BACKFLOW PREVENTION DEVICE TO BE TESTED AND INSPECTED AT LEAST ANNUALLY BY A NYSDOH CERTIFIED BACKFLOW TESTER WITH RESULTS REPORTED TO PORT WASHINGTON WATER DISTRICT USING NYSDOH FORM # DOH-1013'.
7. DISCHARGE FROM BACKFLOW DEVICE TO BE POSITIVE WITH EFFLUENT VISIBLE WITH DISCHARGE ABOVE HIGHEST POSSIBLE FLOODING LEVEL.
8. ALL WATER SERVICE PIPING AND FITTINGS SHALL BE CERTIFIED "LEAD-FREE" MATERIALS.
9. THE PROPOSED BACKFLOW PREVENTION DEVICE SHALL BE LEAD FREE AND SHALL BE FROM A LIST OF APPROVED BACKFLOW PREVENTION DEVICES BY UNIVERSITY OF SOUTHERN CALIFORNIA (USC).
10. BACKFLOW DEVICE TO BE ONE SIZE LARGER WHERE PRESSURE IS LOW OR CRITICAL.
11. BACKFLOW DEVICE SHALL BE INSTALLED IMMEDIATELY AFTER THE METER, IF POSSIBLE. IF THE DEVICE IS NOT IN THE SAME LOCATION AS THE METER, OR IS EVER GREATER THAN 10-FEET FROM THE METER A NOTE STATING THAT ALL PIPING NOT PROTECTED BY BACKFLOW DEVICES SHALL BE STENCILED "FEED LINE TO RPZ/DCV DO NOT TAP" AT 5-FOOT INTERVALS.
12. METER PIT SHALL BE KEPT FREE OF SOIL AND DEBRIS.

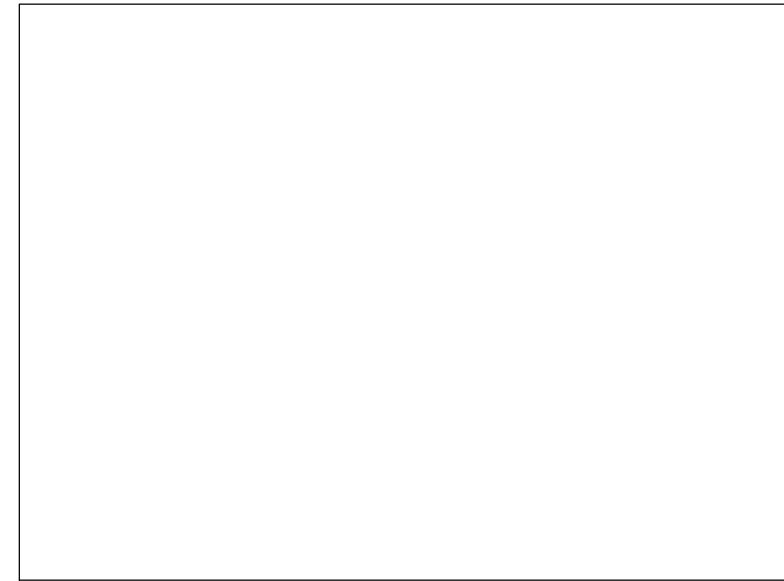

PROPOSED BACKFLOW PREVENTION DEVICE

MANUFACTURER _____ MODEL _____

ADDRESS _____

ENDORSED BY THE PORT WASHINGTON WATER DISTRICT FOR INSTALLATION OF A _____ (SIZE) DOUBLE CHECK VALVE

BY _____ DATE: _____



BRUCE A. BLAKEMAN
NASSAU COUNTY EXECUTIVE



NASSAU COUNTY DEPARTMENT OF HEALTH

Cross-Connection Control Plan Review Fees

Fee Schedule
(Effective August 1, 2012)

<u>Project Type</u>	<u>Fee Amount</u>
Double Check Valve (Residential)	- \$140 per device
Double Check Valve (Non-Residential)	- \$275 per device
¾ to 2” Reduced Pressure Zone Device	- \$275 per device
Greater than 2” Reduced Pressure Zone Device	- \$485 per device
Expedited Review of Cross- Connection Control Plans	
Custom Plans	- \$250 additional

All plans received must be accompanied by a check made out to “Nassau County Department of Health” for the appropriate dollar amount.



2018 NACCHO LOCAL HEALTH DEPARTMENT OF THE YEAR
200 COUNTY SEAT DRIVE, MINEOLA, NEW YORK 11501
Phone: 516-227-9692 Fax: 516-227-9613



NASSAU COUNTY MINIMUM PLAN NOTES AND COMMENTS
FOR BACKFLOW DEVICE INSTALLATION PLANS

Please complete the New York State DOH-347 Application for Approval of Backflow Prevention Devices and submit 4 copies of the application/plans with the water supplier's endorsement for approval.

I. Minimum notes required on plans

- _____ A. DCV/RPZ installation to meet all NCHD and NYSHD requirements.
- _____ B. Devices must not be subject to flooding or freezing.
- _____ C. Piping to be unbranched and unrestricted from main to device except for meter.
- _____ D. Devices must be tested at least annually by a NYSHD certified tester.
- _____ E. Drainage to be positive with effluent visible (RPZ only).

II. Clearances Required (Provide actual dimensions on plans)

- _____ A. 30" minimum from centerline of device to floor (ALL).
- _____ B. 30" minimum from device to any obstructions (ALL).
- _____ C. 8" minimum from edge of device to wall (ALL).
- _____ D. 18" minimum from relief spout to floor (RPZ only).
- _____ E. Building dimensions (ALL).
- _____ F. Room or pit dimensions - as applicable (ALL).

III. Comments

- _____ A. **Device must be immediately after water meter.**
- _____ B. P.E. or R.A. seal on plans.
- _____ C. State make, model # and size of device on plans.
- _____ D. Identify premises on plans.
- _____ E. Show two views of device - plan and section.
- _____ F. Show accurate testcock location.
- _____ G. Show grade on all plans.
- _____ H. Drainage details for RPZ **must be shown**. How will water be disposed of?

- _____ I. Provide site plan (Street, water main, service line, location of meter and device. All service lines must be shown with sizes).
- _____ J. Leave adequate space for NCDH approval stamp.
- _____ K. All material to be submitted in quadruplicate.

IV. Devices must be located directly after the water meter if possible. If the device is not located in the same location as the meter, or if there is no meter, a note stating that all piping not protected by the backflow device shall be stenciled "Feed Line To RPZ/DCV Do Not Tap" at 5 foot intervals.